

M20x1.5 Thermostats for mounting in cable glands holes or threads, for boxes external ambient temperature control

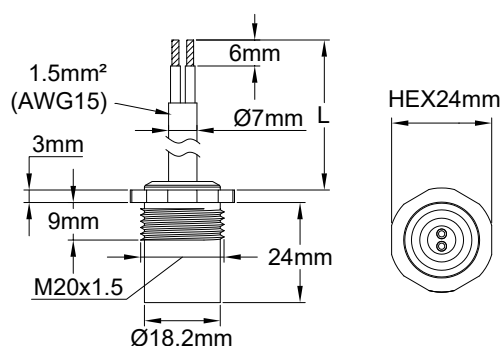

Because of permanent improvement of our products, drawings, descriptions, features used on these data sheets are for guidance only and can be modified without prior advice

Thread	Body diameter	Wire gauge	Sensors	Body material	Type
M20 × 1.5	Ø18.2 × 15mm	0.5mm ² (AWG24)	Disc thermostat	Anodized aluminum	49JB



Through cabinet wall assembly versions

In a M20x1.5 thread	In a 20mm diameter drill	In a M20x1.5 thread (gasket in red)	In a 20mm diameter drill (Nut in green)

Applications

These fixed setting thermostats have been designed to be mounted in holes dia. 20mm (With a lock nut and a gasket) or in M20x1.5 threads (With a gasket), originally intended for mounting cable glands on connection boxes or control boxes. **They allow to easily install an ambient temperature control on these boxes, usually used as an anti-freeze function.** The ambient temperature measurement is then made outside, 15mm from the wall, and the system is fully waterproof.

Main features

Housing: Black anodized aluminum with M20x1.5 thread.

Ingress protection: IP66.

Connection: 1.5mm² two-conductor cable (AWG15), 300V insulation.

Temperature set point:

Open: 10 +/- 3 °C (Heating off).

Close: 4 +/- 3 °C (Heating on).

Other temperatures on request, consult us.

Electric rating: 16A 250V, 10,000 cycles.

Accessories:

M20 x1.5 Nylon nut		66NDM20545H25
70 shore NBR gasket		66JPN18518265

References

Cable length (L)			
300mm	1m	2m	3m
49JBDJ01006KFRF8	49JBDJ01006KFR18	49JBDJ01006KFR28	49JBDJ01006KFR38

Note: Some versions of these thermostats for applications to control ambient temperature in hazardous areas (dust or gas) are described in the catalogue 4. The thread is then M22x1.5 instead of M20x1.5, and products family reference becomes 4V.